

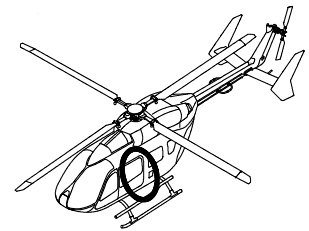

ALERT SERVICE BULLETIN

SUBJECT: DOORS AND SERVICE COVERS - Jettisonable Sliding Doors

Replacement of the upper lever and middle lever

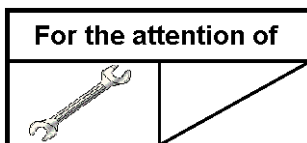

Revision No.	Date of issue
Revision 0	2014-05-26

Summary:

With this Alert Service Bulletin, the replacement of the upper and middle levers against an improved design will be introduced.

Compliance:

The compliance with this Alert Service Bulletin is essential.

1. PLANNING INFORMATION

1.A. EFFECTIVITY

1.A.1. Helicopters/installed equipment

- (a) MBB-BK117 C-2, with jettisonable sliding doors, S/N 9004 up to and including S/N 9621.
- (b) Upper Lever welded LH P/N B522M3133801 or
Upper Lever welded RH P/N B522M3134801
Middle Lever preassy LH P/N B522M3183101 or
Middle Lever preassy RH P/N B522M3184101

1.A.2. Non-installed equipment

See Section 1.A.1.

1.B. ASSOCIATED REQUIREMENTS

Not applicable.

1.C. REASON

After a maintenance action on several jettisonable sliding doors further unintentional releases were reported. These incidents have been attributed to incorrect installation of the jettisonable sliding doors. With this Alert Service Bulletin the replacement of the upper lever and middle lever with an improved design is introduced. The improved design prevents the installation of the jettisonable sliding door if an incorrect adjustment has been made.

1.D. DESCRIPTION

Remove the jettisonable sliding doors. Remove the upper levers and the middle levers. Install the improved upper levers and middle levers. Install the jettisonable sliding doors IAW AMM and additionally with the Safety Information Notice 2658-S-52.

1.E. COMPLIANCE

1.E.1. Compliance at the works

Helicopters/installed equipment:

Not applicable.

Non-installed equipment:

Not applicable.

1.E.2. Compliance in service

Helicopters/installed equipment:

The replacement of the upper levers and the middle levers IAW Section 3.B.1 must be accomplished **within the next 12 month** after receipt of this Alert Service Bulletin.

Non-installed equipment:

The replacement of the upper levers and the middle levers IAW Section 3.B.1 must be accomplished **before the installation** of the jettisonable sliding doors in the helicopter at the latest.

1.F. APPROVAL
Approval of modification(s):

The information or instructions contained in this document refer to change no. 2937. The technical content of this document is approved under the authority of DOA No. EASA.21J.034.

1.G. MANPOWER

Qualification	Mechanic	Electrician	Pilot	Others
Time for operations (LH and RH)	approx. 4 h	-	-	-

1.H. WEIGHT AND BALANCE
EFFECTIVITY Retrofit kit SB-117C2-52A-018-2C1.

Weight: +0.063 kg

Arm longitudinal: +2924 mm Moment longitudinal: +184 kgmm

Arm lateral: -744 mm Moment lateral: -47 kgmm

EFFECTIVITY Retrofit kit SB-117C2-52A-018-2C2.

Weight: +0.063 kg

Arm longitudinal: +2924 mm Moment longitudinal: +184 kgmm

Arm lateral: +744 mm Moment lateral: +47 kgmm

1.I. EFFECT ON ELECTRICAL LOADS

Not applicable.

1.J. SOFTWARE MODIFICATION EMBODIMENT RECORD

Not applicable.

1.K. REFERENCES

AMM MBB-BK117 C-2

Safety Information Notice 2658-S-52

1.L. DOCUMENTS AFFECTED

Not applicable.

1.M. INTERCHANGEABILITY OR MIXABILITY OF PARTS
Interchangeability:

The old upper levers and middle levers must not be installed into the jettisonable sliding doors after accomplishment of this Alert Service Bulletin.

Mixability:

It is not admissible to mix the old upper and middle levers and the improved upper and middle levers.

2. MATERIAL INFORMATION

2.A. MATERIAL: PRICE - AVAILABILITY - PROCUREMENT

Information on price and availability of required retrofit kit SB-117C2-52A-018-2C1 and SB-117C2-52A-018-2C2 will be provided by Airbus Helicopters Deutschland, Dept. Spares Order Administration on request.

2.B. INFORMATION CONCERNING INDUSTRIAL SUPPORT

The retrofit kits will be provided by Airbus Helicopters Deutschland free of charge within the accomplishment period (see Section 1.E.2).

2.C. MATERIAL REQUIRED FOR EACH HELICOPTER/COMPONENT

Kits or components to be ordered for one helicopter or one assembly:

EFFECTIVITY Jettisonable sliding door LH

Retrofit kit SB-117C2-52A-018-2C1 similar to design document B522M3331106.

No.	Keyword	Qty	New P/N	Old P/N	Remark
1	Upper Lever Welded LH	1	B522M3133802	-	-
			-	B522M3133801	A
2	Middle Lever Preassy LH	1	B522M3183103	-	-
			-	B522M3183101	A
3	Anchor	1	B522M3137202	-	-
			-	B522M3137201	A
4	Coil Spring	1	B522M3183210	-	-
	Disc Spring	4	-	DIN2093-A12,5	A
5	Bushing	1	B522M3183201	-	-
6	Hexagon Washer Nut	1	LN9338-06	-	-
			-	LN9338-06	A

EFFECTIVITY Jettisonable sliding door RH

Retrofit kit SB-117C2-52A-018-2C2 similar to design document B522M3332106.

No.	Keyword	Qty	New P/N	Old P/N	Remark
1	Upper Lever Welded RH	1	B522M3134802	-	-
			-	B522M3134801	A
2	Middle Lever Preassy RH	1	B522M3184103	-	-
			-	B522M3184101	A
3	Anchor	1	B522M3137202	-	-
			-	B522M3137201	A
4	Coil Spring	1	B522M3183210	-	-
	Disc Spring	4	-	DIN2093-A12,5	A
5	Bushing	1	B522M3183201	-	-
6	Hexagon Washer Nut	1	LN9338-06	-	-
			-	LN9338-06	A

Remark:

A = Part with old P/N is discarded. Discarded Parts are not taken back by Airbus Helicopters Deutschland.

Products to be ordered separately:

Products have to be ordered from the INTERTURBINE AVIATION LOGISTICS company. The given CM numbers are IAW the AMM list of consumable materials.

 Website: <http://www.interturbine.com>

Phone: +49.41.91.809.300

AOG: +49.41.91.809.444

No.	Keyword	Qty. (approx.)	Specification **	CM	Rem.
1	Lacquer, single-layer	a.n.*	-	421	-
* a.n. = as needed ** Specification IAW AMM, 01-00-00, 2-1.					

2.D. MATERIAL TO BE RETURNED

Not applicable.

3. ACCOMPLISHMENT INSTRUCTIONS

3.A. GENERAL

Not applicable.

3.B. OPERATIONAL PROCEDURE

3.B.1. Procedure

NOTE The following procedure is described for the LH jettisonable sliding door. The procedure for the RH jettisonable sliding door is identical.

- (a) Remove the door guides IAW AMM, 52-12-00, 4-2, step 3.
- (b) Discard the old middle lever. The new middle lever will be delivered as an assy.
- (c) Remove the old upper lever from the upper car:
 - 1 Remove the hexagon head screw (2, Figure 1) together with the nut (6) and the washer (5). Store the hexagon head screw, the nut and the washer for reuse.
 - 2 Remove the countersunk screw (3, Figure 1). Store the countersunk screw for reuse.
 - 3 Remove the upper lever (4, Figure 1) from the upper car (1). Discard the old upper lever.
- (d) Assemble the new upper lever:
 - 1 Install the anchor (6, Figure 2) to the upper lever (1).
 - 2 Install the bushing (5, Figure 2) and the coil spring (4).
 - 3 Install the hexagon washer nut (2, Figure 2) to the anchor (6) so that the hexagon washer nut just engages on the last thread of the anchor.

NOTE Additional information for the installation of the jettisonable sliding door can be found in **Safety Information Notice 2658-S-52 and the therein contained 3D tutorial** <http://youtu.be/XpiKgH9n7so>

NOTE With the improved design of the upper lever and the middle lever, the four disc springs will be replaced by a coil spring and an additional bushing (see Figure 2).

- (e) Install the new upper and new middle door guides IAW AMM, 52-12-00, 4-2, step (4)(i) and up, with exception of step (4)(p)1, (4)(p)2 and the Caution in front of these steps. Instead of these steps proceed as follows:
 - 1 Tighten the hexagon washer nut (1, Figure 3) of the upper lever and middle lever until the hexagon washer nuts (1) touches the bushings (2).
 - 2 Release the hexagon washer nuts (1, Figure 3) of the upper and middle lever by three quarters of a turn.
- (f) Identification of the jettisonable sliding door:
 - 1 Using a permanent pen, identify the jettisonable sliding door with "ASB MBB-BK117 C-2-52A-018" IAW Figure 4. Apply a layer of lacquer, single layer (CM 421) to protect the identification. Leave it to dry IAW the manufacturers instruction.

3.C. IDENTIFICATION

Identification of this document:

Confirm accomplishment of this Alert Service Bulletin by an entry in the historical record of the helicopter.

Identification of modification of equipment:

Keyword	Old P/N	New P/N	MOD	Marking Type
Jettisonable sliding door	-	-	ASB MBB-BK117 C-2-52A-018	Permanent pen

4. APPENDIX

Not applicable.

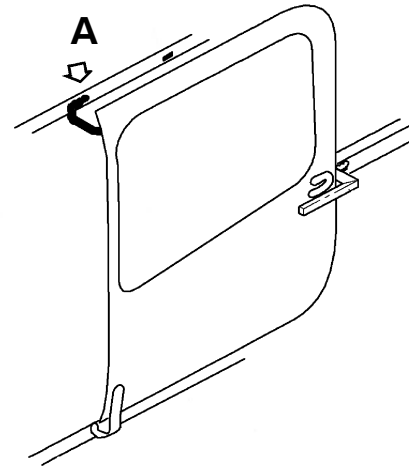
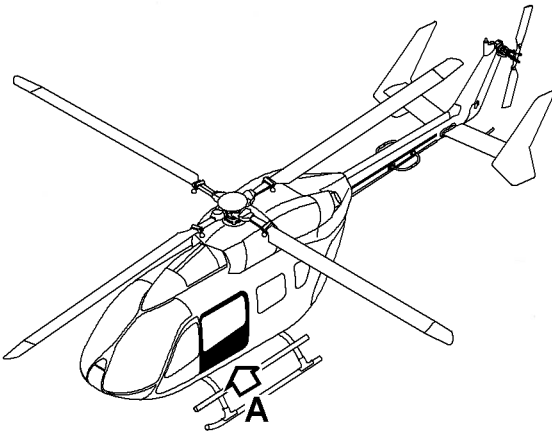

Without locking mechanism.

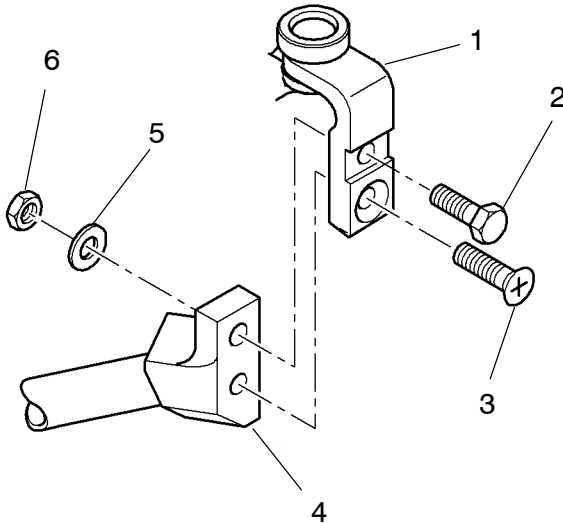





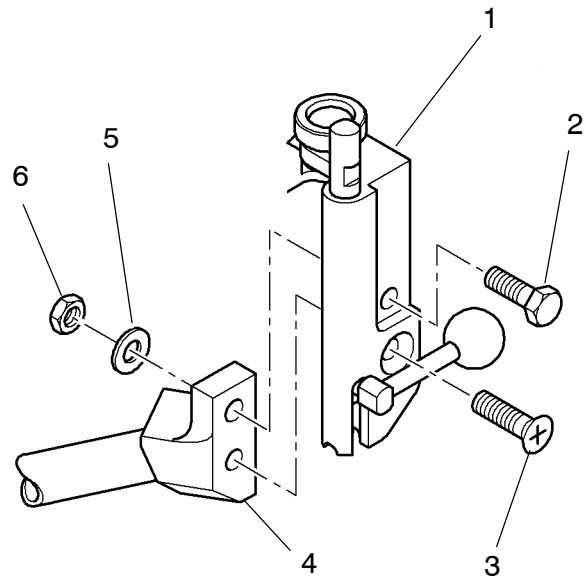

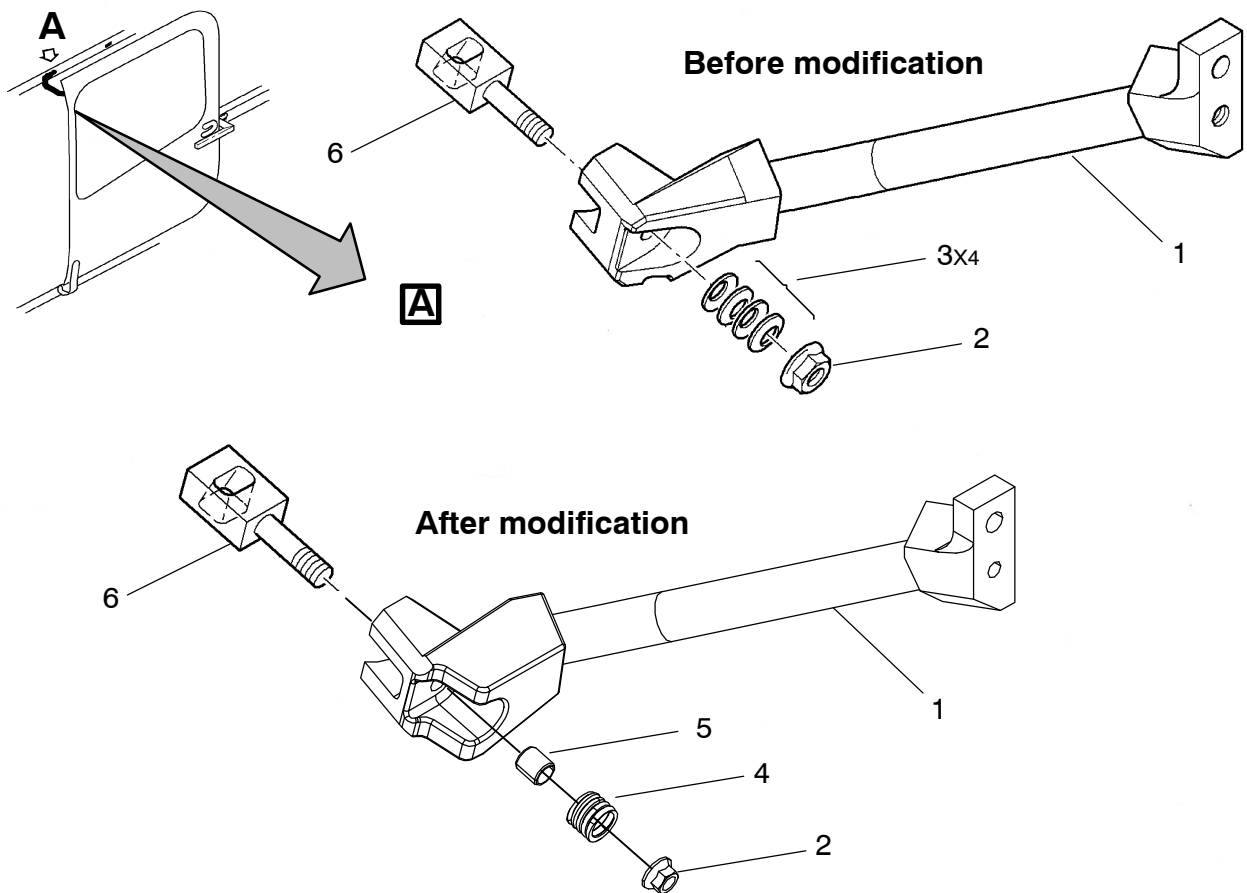

- 1 Upper car
- 2 Hexagon head screw
- 3 Countersunk screw
- 4 Upper lever
- 5 Washer
- 6 Nut

With locking mechanism.



Removal Upper lever
Figure 1



1 Upper lever welded	B522M3133802	
	B522M3133801	
2 Hexagon washer nut	LN9338-06	
3 Spring discs	DIN2093A12,5	
4 Coil spring	B522M3183210	
5 Bushing	B522M3183201	
6 Anchor	B522M3137202	
	B522M3137201	

 After modification.

 Before modification.

Modification Upper Lever
Figure 2

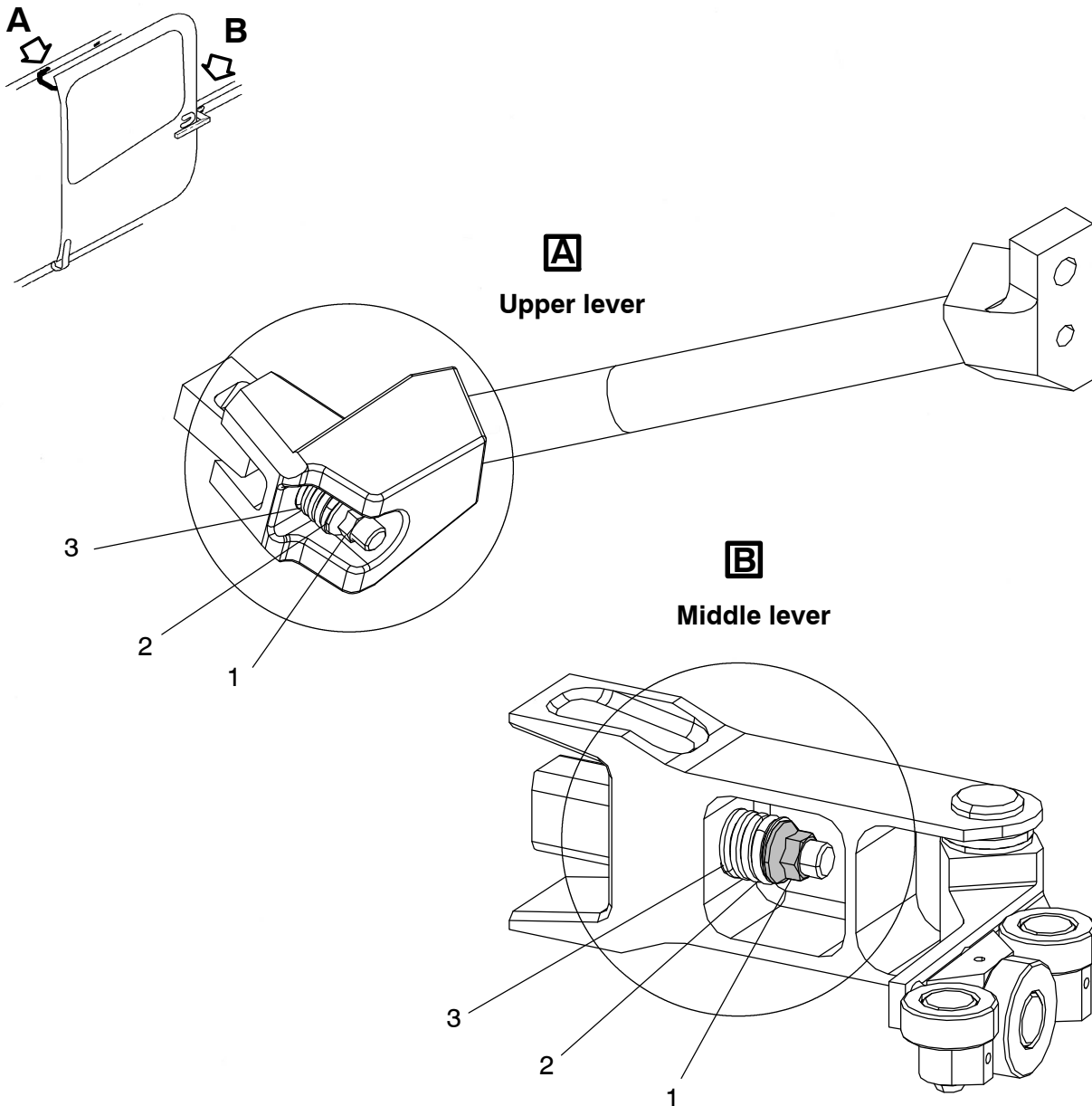

- 1 Hexagon washer nut
- 2 Bushing
- 3 Coil spring

Adjust upper lever and middle lever
Figure 3

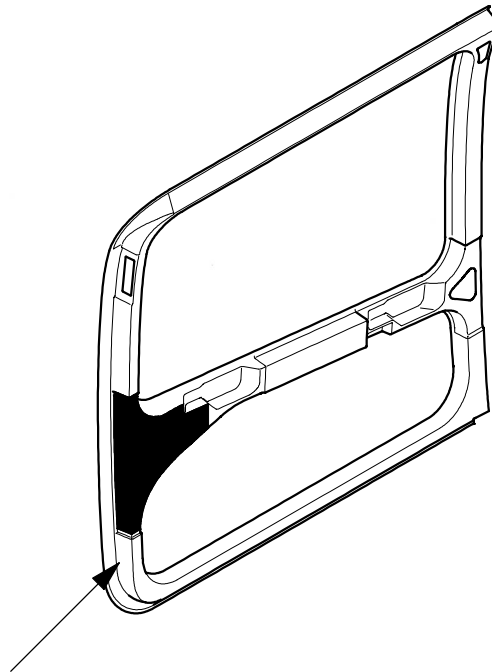
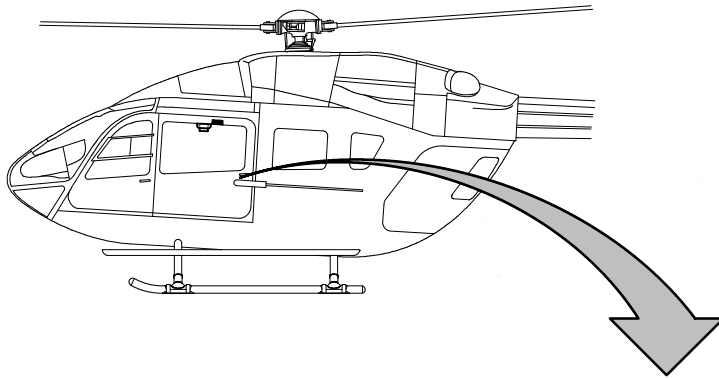

Write the number of this Alert Service Bulletin "ASB MBB-BK117 C-2-52A-018".

Identification Jettisonable Sliding Door
Figure 4